

SR NO	PART NUMBER	DESCRIPTION	A (INCH)	B (INCH)	C (INCH)	D (INCH)
1	S100	STRAP KIT 1" CONDUIT WITH 1/2" BOLTS NUTS WASHERS (20/BOX)	1-3/8	2-15/16	4-1/16	1-9/32
2	S150	STRAP KIT 1.50" CONDUIT WITH 1/2" BOLTS NUTS WASHERS (20/BOX)	1-31/32	3-17/32	4-21/32	1-27/32
3	S200	STRAP KIT 2" CONDUIT WITH 1/2" BOLTS NUTS WASHERS (20/BOX)	2-7/16	4	5-1/8	2-9/32
4	S250	STRAP KIT 2.50" CONDUIT WITH 1/2" BOLTS NUTS WASHERS (20/BOX)	2-15/16	4-1/2	5-29/32	2-25/32
5	S300	STRAP KIT 3" CONDUIT WITH 1/2" BOLTS NUTS WASHERS (20/BOX)	3-19/32	5-1/8	6-1/4	3-13/32
6	S350	STRAP KIT 3.50" CONDUIT WITH 1/2" BOLTS NUTS WASHERS (20/BOX)	4-1/16	5-5/8	6-3/4	3-31/32
7	S400	STRAP KIT 4" CONDUIT WITH 1/2" BOLTS NUTS WASHERS (20/BOX)	4-9/16	6-1/8	7-1/4	4-13/32
8	S500	STRAP KIT 5" CONDUIT WITH 1/2" BOLTS NUTS WASHERS (20/BOX)	5-5/8	7-3/16	8-5/16	5-17/32
9	S600	STRAP KIT 6" CONDUIT WITH 1/2" BOLTS NUTS WASHERS (20/BOX)	6-11/16	8-1/4	9-3/8	6-17/32

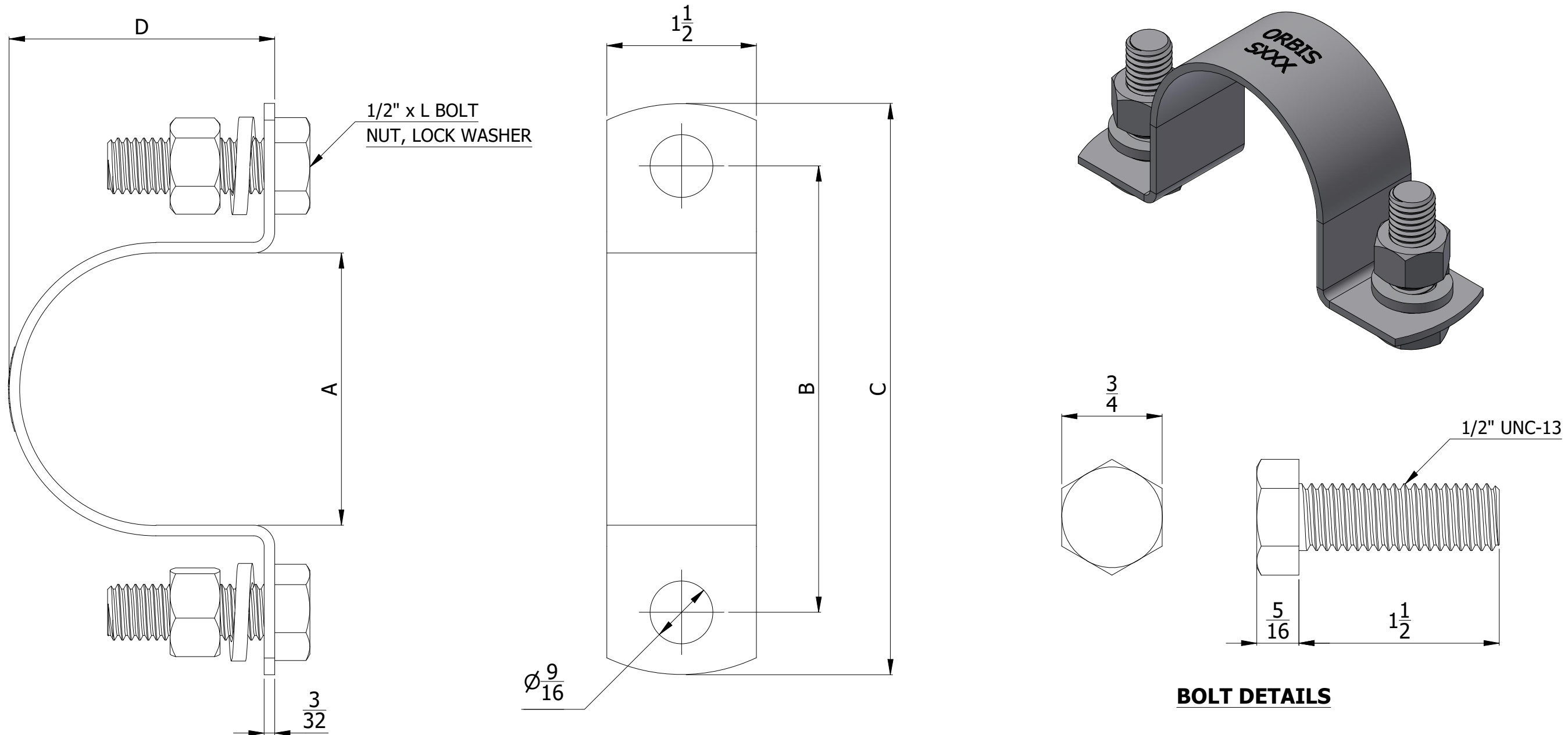

**NOTES:**

- MATERIAL: CLAMP - ALUMINIUM
- HARDWARE: HOT DIP GALVANIZED AS PER ASTM A153  
 BOLT: 3/4" HEX HEAD, 1/2" UNC-13 CLASS 2 X 1-3/4" GRADE 5  
 LOCK WASHER: 1/2" SINGLE COIL LOCK WASHER.  
 NUT: 1/2" HEX NUT UNC-13 CLASS 2

THIS DRAWING CONTAINS CONFIDENTIAL INFORMATION AND IS THE EXCLUSIVE PROPERTY OF ORBIS MANUFACTURING



DRAWN	MSM	DATE	28-07-2022
APPROVED	DMM	DATE	04-08-2022
REVISION	DMM	R1.1	02-09-2024

**DRAWING NUMBER**

SXXX

**DESCRIPTION**

STRAP KIT X" CONDUIT WITH 1/2" BOLTS NUTS WASHERS (20/BOX)