

SR NO	PART NUMBER	DESCRIPTION	T	-	E	-	H	H	-	K	-
			NUT SIZE	NOM.	MIN.	MAX.	MIN.	MAX.	NOM.	MIN.	MAX.
1	BNS100	NUT SQUARE 1" HDG	1	1-1/2"	1.45"	1.5"	1.961"	2.121"	7/8"	0.847"	0.903"
2	BNS12	NUT SQUARE 1/2" HDG	1/2	13/16"	0.788"	0.812"	1.052"	1.149"	7/16"	0.418"	0.458"
3	BNS34	NUT SQUARE 3/4" HDG	3/4	1-1/8"	1.088"	1.125"	1.464"	1.591"	21/32"	0.632"	0.680"
4	BNS58	NUT SQUARE 5/8" HDG	5/8	1	0.969"	1"	1.3"	1.414"	35/64"	0.525"	0.569"
5	BNS78	NUT SQUARE 7/8" HDG	7/8	1-5/16"	1.269"	1.312"	1.712"	1.856"	49/64"	0.740"	0.792"

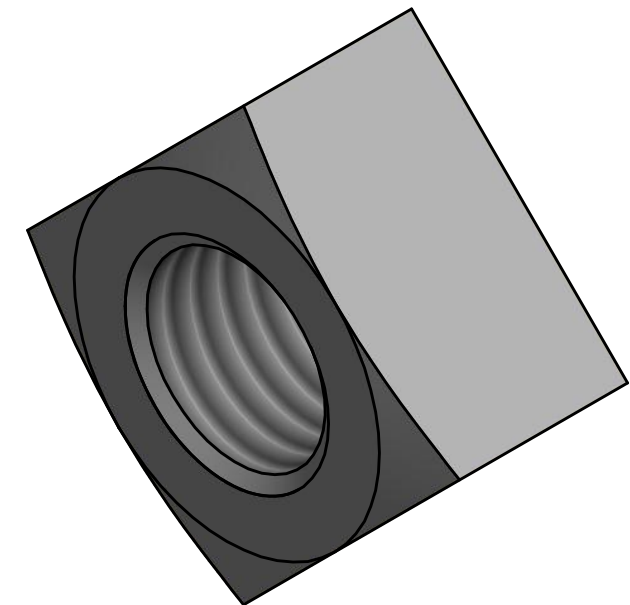
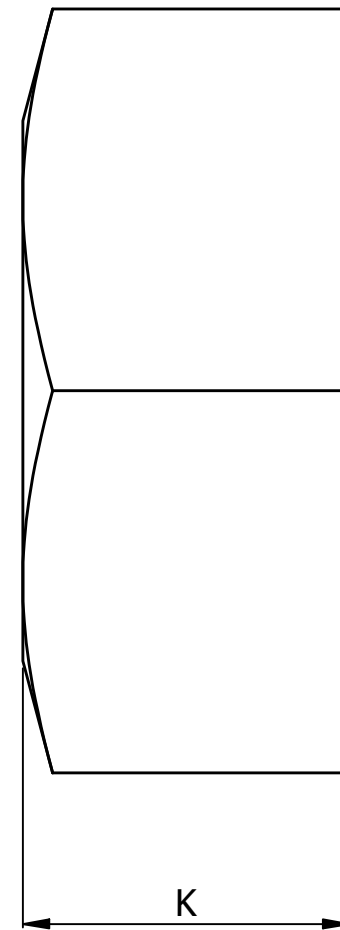
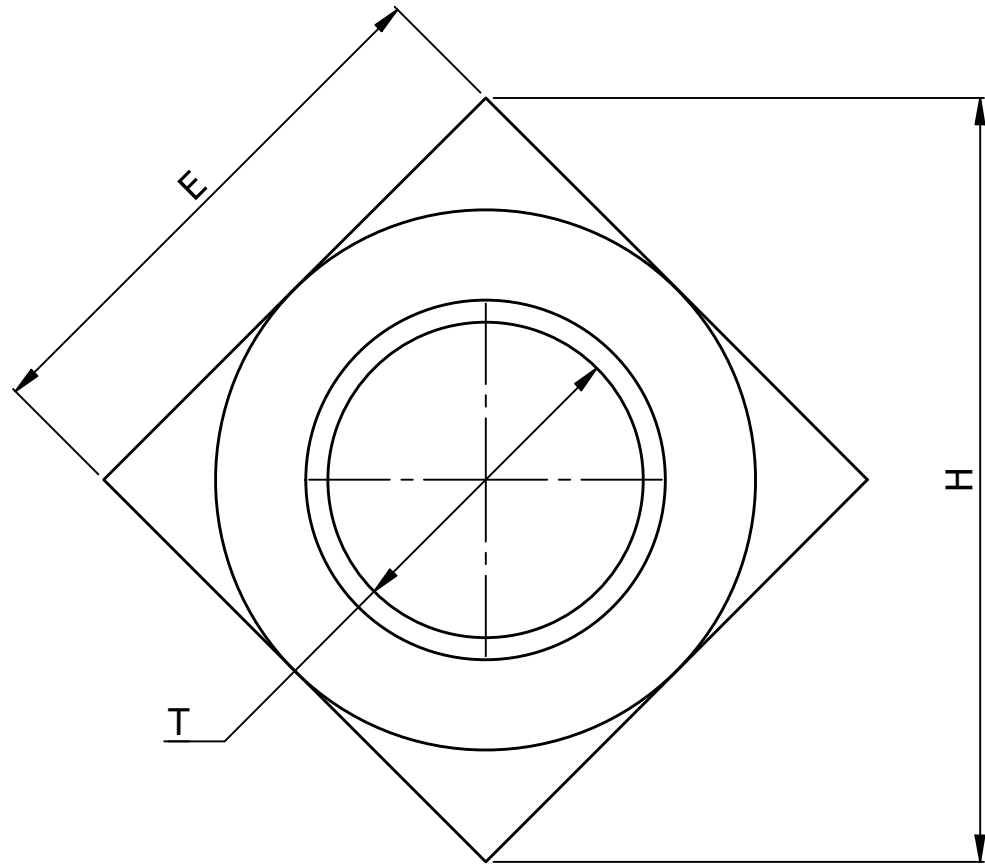

NOTE:
MATERIAL: STEEL - ANSI C135.1
GALVANIZED AS PER ASTM A153
THREADS: 1/2" UNC CLASS-5; 5/8"-1" UNC CLASS-2

THIS DRAWING
CONTAINS
CONFIDENTIAL
INFORMATION
AND IS THE
EXCLUSIVE
PROPERTY OF
ORBIS
MANUFACTURING

ORBIS

DRAWN	MSM	DATE	27-07-2022
APPROVED	DMM	DATE	03-08-2022
REVISION	-		

DRAWING NUMBER

BNSXX

DESCRIPTION

NUT SQUARE HDG