

SR NO	PART NUMBER	DESCRIPTION	T	-	F	-	G	G	-	H	-
			NUT SIZE	NOM.	MIN.	MAX.	MIN.	MAX.	NOM.	MIN.	MAX.
1	BNH100	NUT HEX 1" HDG	1	1-1/2"	1.45"	1.5"	1.653"	1.732"	56/64"	0.831"	0.887"
2	BNH12	NUT HEX 1/2" HDG	1/2	3/4"	0.736"	0.75"	0.84"	0.866"	7/16"	0.427"	0.448"
3	BNH34	NUT HEX 3/4" HDG	3/4	1-1/8"	1.088"	1.125"	1.240"	1.299"	41/64"	0.617"	0.665"
4	BNH58	NUT HEX 5/8" HDG	5/8	15/16"	0.922"	0.938"	1.051"	1.083"	35/64"	0.535"	0.559"
5	BNH78	NUT HEX 7/8" HDG	7/8	1-5/16"	1.269"	1.312"	1.447"	1.516"	3/4"	0.724"	0.776"

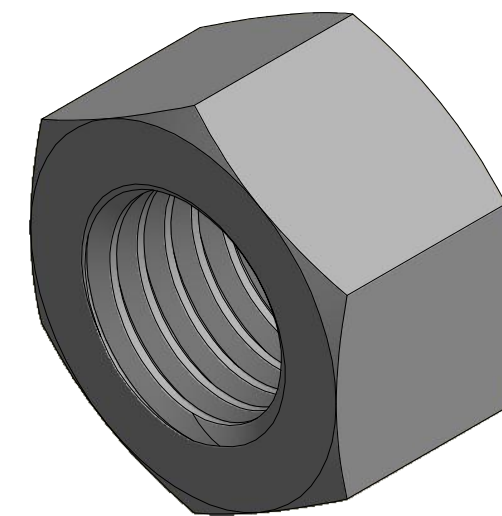
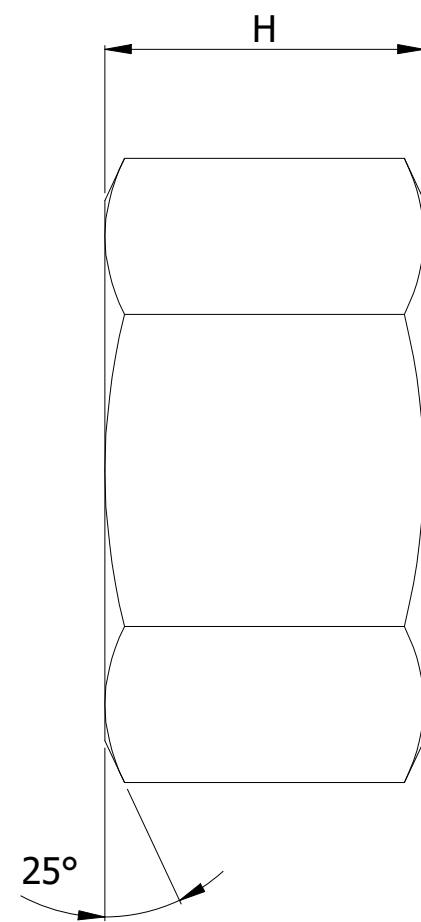
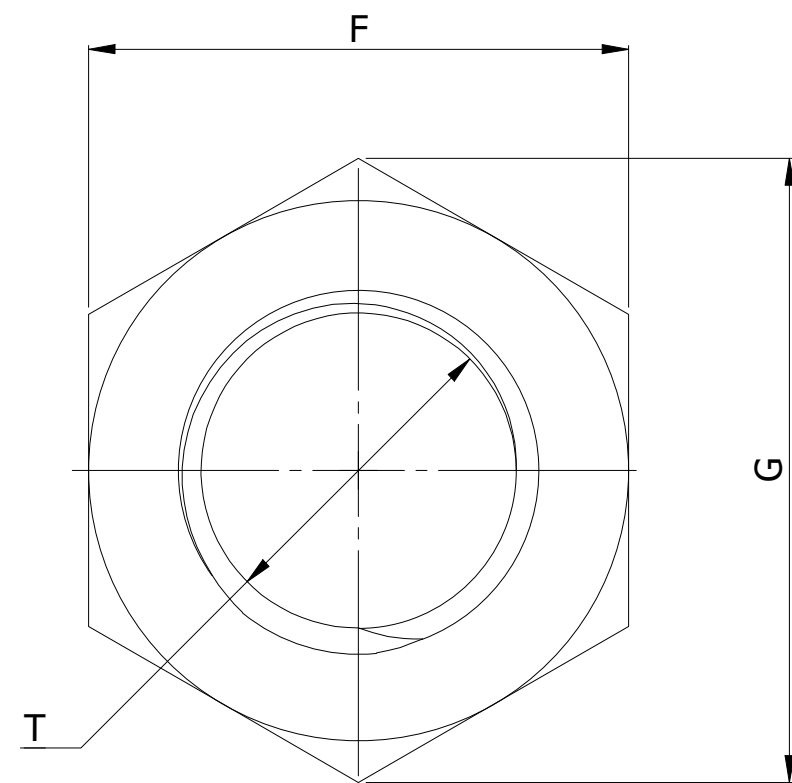

NOTE:
MATERIAL: STEEL - ANSI C135.1
GALVANIZED AS PER ASTM A153
THREADS: 1/2" UNC CLASS-5; 5/8"-1" UNC CLASS-2

THIS DRAWING
CONTAINS
CONFIDENTIAL
INFORMATION
AND IS THE
EXCLUSIVE
PROPERTY OF
ORBIS
MANUFACTURING

ORBIS

DRAWN	MSM	DATE	27-07-2022
APPROVED	DMM	DATE	03-08-2022
REVISION	-		

DRAWING NUMBER

BNHXX

DESCRIPTION

NUT HEX T" HDG