

SR NO	PART NUMBER	DESCRIPTION	L (INCH)	D (INCH)	T (INCH)	S (INCH)
1	BM3406	BOLT MACHINE 3/4" X 6" HDG SQUARE HEAD & NUT	6	3/4	3	3/8
2	BM3408	BOLT MACHINE 3/4" X 8" HDG SQUARE HEAD & NUT	8	3/4	3	3/8
3	BM3410	BOLT MACHINE 3/4" X 10" HDG SQUARE HEAD & NUT	10	3/4	6	3/8
4	BM3412	BOLT MACHINE 3/4" X 12" HDG SQUARE HEAD & NUT	12	3/4	6	3/8
5	BM3414	BOLT MACHINE 3/4" X 14" HDG SQUARE HEAD & NUT	14	3/4	6	3/8
6	BM3416	BOLT MACHINE 3/4" X 16" HDG SQUARE HEAD & NUT	16	3/4	6	3/8
7	BM3418	BOLT MACHINE 3/4" X 18" HDG SQUARE HEAD & NUT	18	3/4	6	3/8
8	BM3420	BOLT MACHINE 3/4" X 20" HDG SQUARE HEAD & NUT	20	3/4	6	3/8
9	BM3422	BOLT MACHINE 3/4" X 22" HDG SQUARE HEAD & NUT	22	3/4	6	3/8
10	BM3424	BOLT MACHINE 3/4" X 24" HDG SQUARE HEAD & NUT	24	3/4	6	3/8
11	BM3426	BOLT MACHINE 3/4" X 26" HDG SQUARE HEAD & NUT	26	3/4	6	3/8
12	BM3428	BOLT MACHINE 3/4" X 28" HDG SQUARE HEAD & NUT	28	3/4	6	3/8
13	BM3430	BOLT MACHINE 3/4" X 30" HDG SQUARE HEAD & NUT	30	3/4	6	3/8
14	BM3432	BOLT MACHINE 3/4" X 32" HDG SQUARE HEAD & NUT	32	3/4	6	3/8
15	BM3434	BOLT MACHINE 3/4" X 34" HDG SQUARE HEAD & NUT	34	3/4	6	3/8
16	BM3436	BOLT MACHINE 3/4" X 36" HDG SQUARE HEAD & NUT	36	3/4	6	3/8

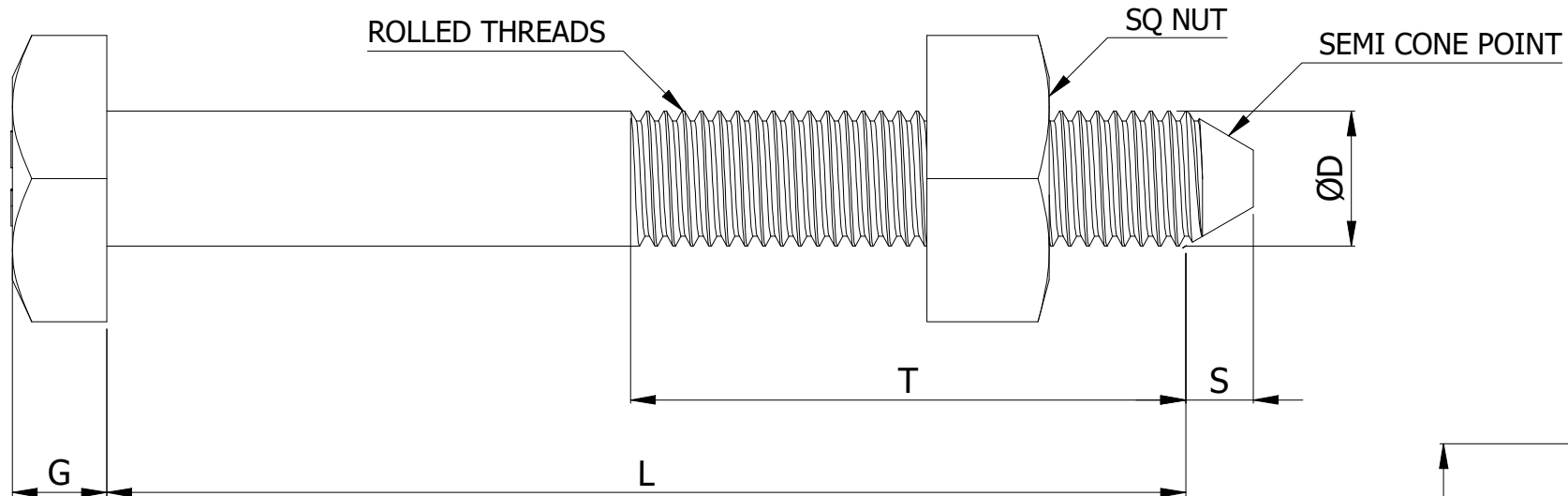
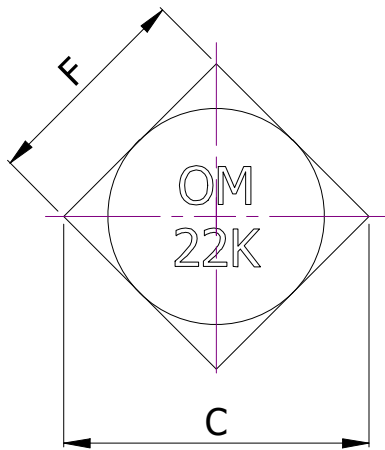

SQUARE BOLT HEAD DIMENSIONS

BOLT	-	F	-	C	C	-	G	-
SIZE	NOM.	MIN.	MAX.	MIN.	MAX.	NOM.	MIN.	MAX.
3/4	1-1/8"	1.088"	1.125"	1.494"	1.591"	12.7	0.476"	0.524"

SQUARE NUT DIMENSIONS

NUT	-	E	-	H	H	-	K	-
SIZE	NOM.	MIN.	MAX.	MIN.	MAX.	NOM.	MIN.	MAX.
3/4	1-1/8"	1.088"	1.125"	1.464"	1.591"	21/32"	0.632"	0.680"

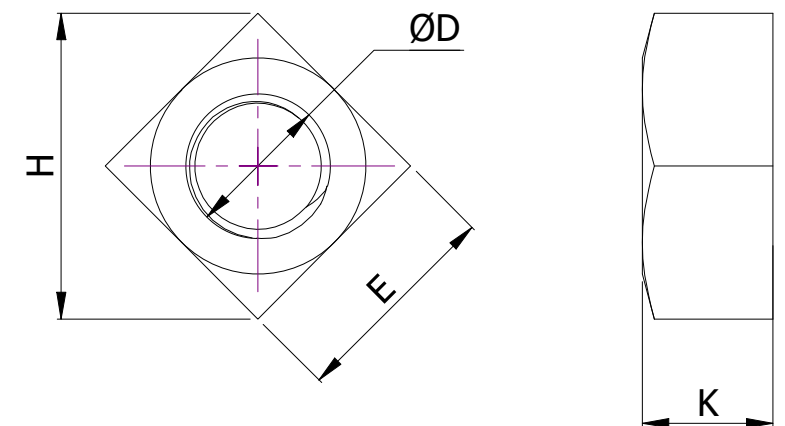

NOTES:

1. MATERIAL: STEEL
2. MINIMUM TENSILE STRENGTH: 22,000 LBS
3. DIMENSIONS: BOLT - ANSI C135.1,
SQ. NUT - ANSI B18.2.2 & ANSI C 135.1
4. THREADS: 3/4" - 10 UNC CLASS-2A
5. FINISH: HOT DIP GALVANIZED AS PER ASTM A153.

THIS DRAWING CONTAINS CONFIDENTIAL INFORMATION AND IS THE EXCLUSIVE PROPERTY OF ORBIS MANUFACTURING



DRAWN	MSM	DATE	22-07-2022
APPROVED	DMM	DATE	27-07-2022
REVISION	1.2		18-01-2023

DRAWING NUMBER

BM34XX

DESCRIPTION

BOLT MACHINE 3/4" X L" HDG SQUARE HEAD & NUT