

SECTION A-A

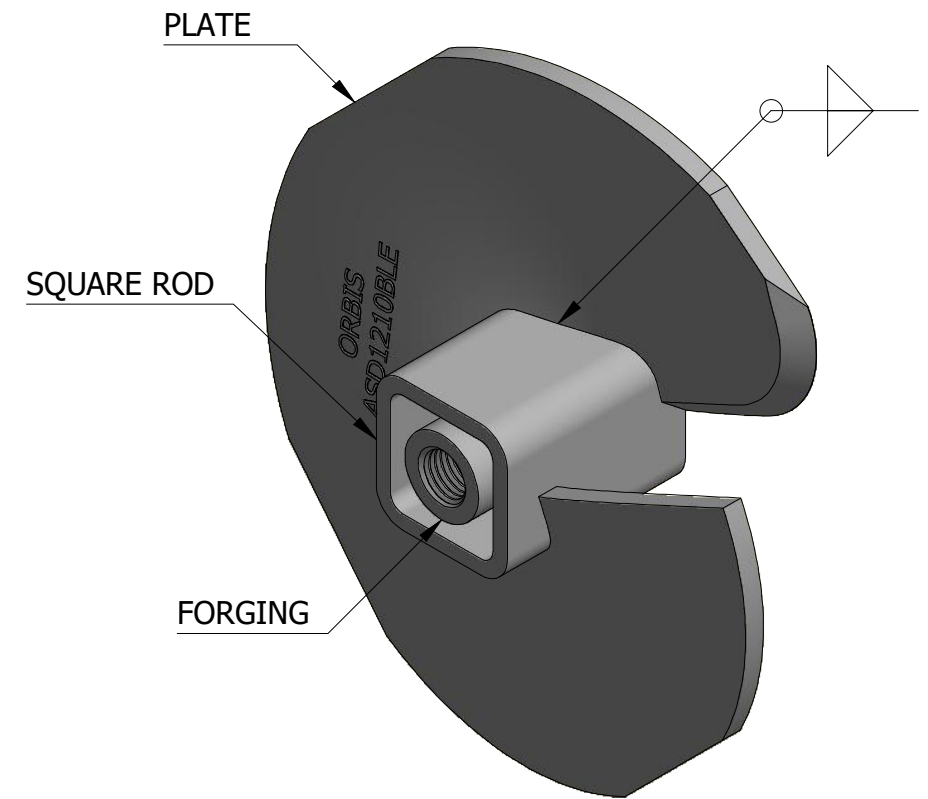

NOTES:

1. MATERIAL: Q355
2. FINISH: GREY PAINT
3. TORQUE RATING: 10,000 FT-LBS (13558 NM)
4. ALL DIMENSIONS ARE IN MM UNLESS SPECIFIED.

THIS DRAWING CONTAINS CONFIDENTIAL INFORMATION AND IS THE EXCLUSIVE PROPERTY OF ORBIS MANUFACTURING



DRAWN	MSM	DATE	18-11-2022
APPROVED	DMM	DATE	26-11-2022
REVISION	-		

DRAWING NUMBER	ASD1210BLE
DESCRIPTION	ANCHOR 12" 10,000 FT LBS SOCKET DRIVE 2-1/4" SQ ID 1" THREAD BEVELED LEADING EDGE