

SECTION A-A

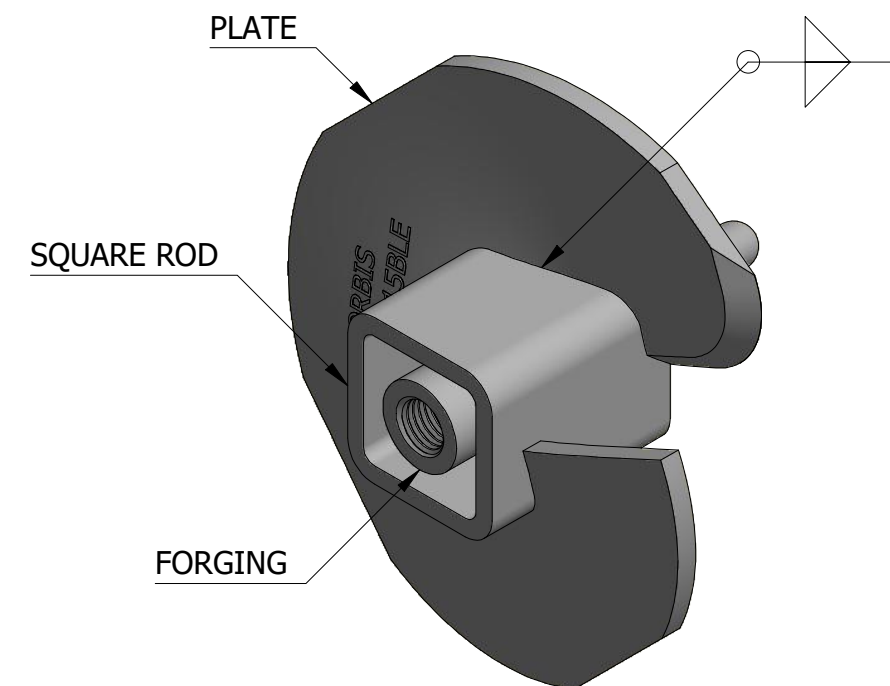

NOTES:

1. FINISH: CORROSION-RESISTANT GREY PAINT.
2. TORQUE RATING: 15,000 FT-LBS.
3. ALL DIMENSIONS ARE IN MM UNLESS SPECIFIED.

THIS DRAWING CONTAINS CONFIDENTIAL INFORMATION AND IS THE EXCLUSIVE PROPERTY OF ORBIS MANUFACTURING



DRAWN	MSM	DATE	18-11-2022
APPROVED	DMM	DATE	24-11-2022
REVISION	-		

DRAWING NUMBER	ASD1015BLE
DESCRIPTION	ANCHOR 10" 15,000 FT LBS SOCKET DRIVE 2-1/2" SQ ID 1" THREAD BEVELED LEADING EDGE